

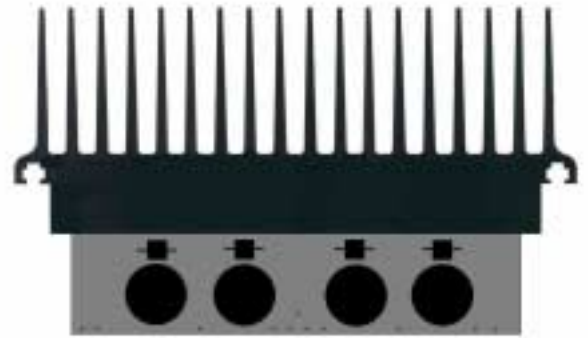

DATA SHEET

HY2007 240 WATTS



The ILP HY2007 Power Amplifier is a fully encapsulated high quality power amplifier with Integral Power Supply and heatsink.

Using the latest Lateral MOSFET's ensures a robust amplifier with excellent sonic characteristics.

Mounting can be achieved by the use of T-slots in the heatsink and the nuts and bolts provided.

TYPICAL SPECIFICATIONS	
Parameter	Value
Output Power	300W rms. Max
Frequency Response (-3dB)	15Hz - 50kHz
Total Harmonic Distortion @ 1kHz	0.005%
Signal to Noise Ratio (DIN AUDIO)	100dB
Slew Rate typical	50V/ μ S
Rise Time	5 μ S
Input Sensitivity	500mV rms.
Input Impedance	100K Ω
Damping Factor(4 Ω @ 100Hz)	>400
Load Impedance	4 Ω
Maximum D.C. rails	\pm 60V
Size Width x Height x Extrusion Cut	190x120x80mm
Weight	1490g

- FEATURES
- Enhanced specifications
- Integral Power Supply
- Anti-thump Circuitry
- Integral heatsink
- Thermal Protection
- PTH Circuit Board
- Encapsulated

POWER SUPPLY REQUIREMENTS

ILP have developed a Hi-Fi quality Low noise Audio Power Toroidal Transformers for the HY2007 which is Low Profile with Resin filled centre for maximum noise absorption and ease of mounting. Finished in black to match the amplifiers this transformer is the ideal choice to power the HY2007.

Mode	Transformer	RMS Supply Voltage	Size	Weight
4 Ω	AT2404	40 - 0 - 40v	130x55mm	4.0Kg

SPONG LANE ELMSTED ASHFORD KENT TN25 5JU
 PHONE +44 (0)1233 750481 FAX +44 (0)1233 750578

ELECTRICAL / MECHANICAL DETAILS AND DIMENSIONS INSTALLATION NOTES

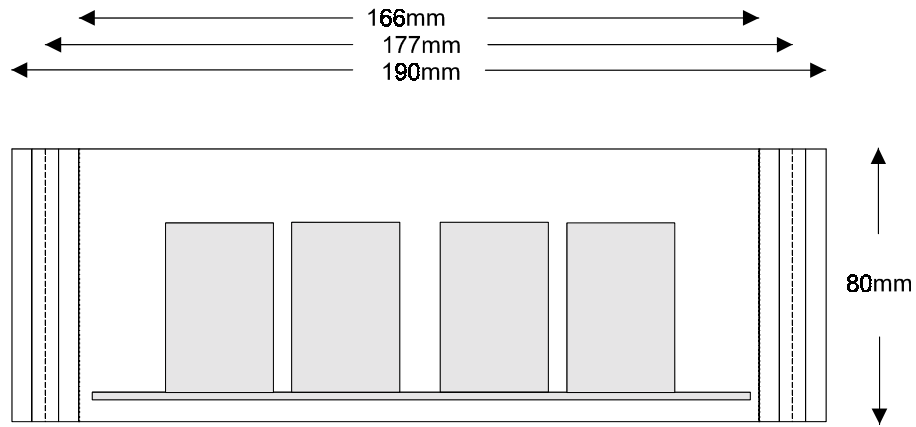

P.C.B TERMINATIONS

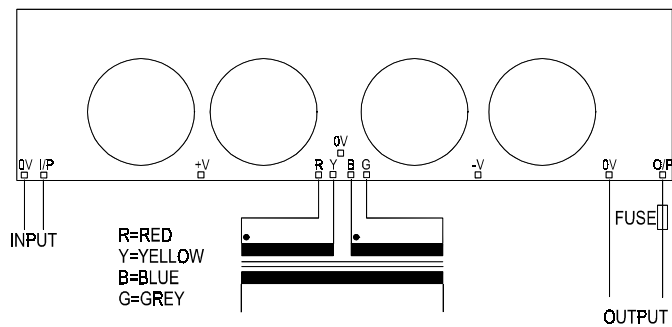

1. For normal usage and conditions the amplifier needs no supplementary heatsink.
2. It must be mounted to allow a vertical flow of air through the fins.
3. No input capacitor is required. An internal 100V working capacitor is fitted.
4. For loudspeaker protection it is recommended that a quickblow fuse is mounted between the output and the speaker. The fuse rating specified has been calculated to ensure fast rupture in the event of DC being presented to the speaker. It is advised not to use a higher rated fuse.
5. The amplifier is designed for 4Ω loads and a 5A quickblow fuse is recommended.